



jardinico®
CARACTÈRE

13401 Brooks Drive, Baldwin Park, CA 91706 | 626-338-8810 | 626-338-8816 fax







www.jardinicousa.com | info@jardinicousa.com

jardinico®
CARACTÈRE



2022



	4	INTRODUCTION
	7	JCP.101 CENTERPOST ALU 7.5 ft. Square / 2.3m x 2.3m 9 ft. Hexagon / Ø 2.8m
	13	JCP.201 CENTERPOST ALU 15 ft. Octagon / Ø 4.5m
	19	JCP.301 SIDEPOST ALU 10 ft. Square / 3.0m x 3.0m 11.5 ft. Octagon / Ø 3.5m
	25	JCP.401 SIDEPOST ALU 10 ft. x 14 ft. Rectangle / 3.0m x 4.3m 13 ft. Octagon / Ø 4.0m
	31	JCP.501 QUAD SIDEPOST ALU (4) 10 ft. Square / (4) 3.0m x 3.0m
	36	FINISHES & FABRICS
	37	BASE & MOUNT OPTIONS
	38	ACCESSORIES
	39	REPLACEMENT PARTS & OPTIONS AND MAINTENANCE
	40-42	TERMS & CONDITIONS
	43	WARRANTY
	44-45	SPECIFICATIONS

INTRODUCTION

True elegance is redefined in each umbrella with sleek lines and a slim stature. Designed and executed flawlessly down to the finest details, these shade statements incorporate an equally robust construction built for demanding applications. An array of color and finish options allows for effortlessly matching to other outdoor furnishings and elements. With shades that are uniquely taut and boast an impeccable finish, the umbrellas provide superior functionality and an ease of opening with a simple twist of the hand. Made to last for years to come, these innovative umbrellas do not just protect against the sun; but also embody beauty and elegance that serves as the finishing touch for any outdoor setting.

That is Jardinico® Caractère.





FEATURES:

- Extra sturdy, aluminum frame with a thickness of up to 3.0mm.
- 360° rotation (most styles).
- Seamless transition from post to base.
- Simple, minimalist, powder coated, hot galvanized steel base with all weather wheels that rotate.
- Locking wheels on base.
- Self-locking canopy fasteners.
- Protective cover included.

Shade as a style statement.



For accessories, see page 38.







SHOWN: JCP101-28 (CC - Charcoal) in 10022 Natté Grey Chiné

JCP.101 CENTERPOST ALU



6.42 ft (1.96m) 7.44 ft (2.27m)



6.81 ft (2.08m) 7.63 ft (2.33m)

For finish & fabric options, see page 36.

ITEM NO.	SIZE	WEIGHT	CANOPY SHAPE	RIBS	FEATURES	MSRP
JCP101-23S	7.5 ft x 7.5 ft (2.3m x 2.3m)	23 lbs.	Square	4	<ul style="list-style-type: none"> Aluminum Magnodraulic Push-Up Lift System Single Wind Vent Protective Cover 	\$1,760
JCP101-28	9 ft (2.8m)	27 lbs.	Hexagon	6	<ul style="list-style-type: none"> Self-Locking Canopy Fasteners 	\$1,760

ITEM NO.	DESCRIPTION	WEIGHT	SIZE	FEATURES	MSRP
JCB101	Freestanding Base	100 lbs.	19.68" x 19.68" x 3.14"	<ul style="list-style-type: none"> Powder Coated Hot Galvanized Steel Base 1.88" Locking Wheels 	\$1,130*

*Compatible base must be purchased with frame & canopy. Mount kit option not available.











SHOWN: JCP201-45 (MW - Matte White) in 10020 Natté White

JCP.201 CENTERPOST ALU

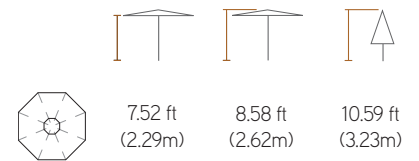

For finish & fabric options, see page 36.

ITEM NO.	SIZE	WEIGHT	CANOPY SHAPE	RIBS	FEATURES	MSRP
JCP201-45	15 ft (4.5m)	82.5 lbs.	Octagon	8	<ul style="list-style-type: none"> Aluminum Telescopic Crank Lift System Self-Locking Canopy Fasteners Single Wind Vent Internal Mast Stem Cover Protective Cover 	\$6,665
ITEM NO.	DESCRIPTION	WEIGHT	SIZE	FEATURES	MSRP	
JCB201	Freestanding Base	350 lbs.	39.37" x 39.37" x 6.29"	<ul style="list-style-type: none"> Powder Coated Hot Galvanized Steel Base 3.75" Locking Wheels 	\$3,125*	

*Compatible base or mount kit must be purchased with frame & canopy. For available mount kit options, see page 37.







JCP.301





SHOWN: JCP301-35 (CC - Charcoal) in 5476 Heather Beige

JCP.301 SIDEPOST ALU



Infinite Tilt
Front to Back, Left to Right



6.89 ft
(2.10m)

7.64 ft
(2.33m)

12.64 ft
(3.85m)

9.73 ft
(2.97m)

3.89 ft
(1.19m)



7.06 ft
(2.15m)

7.58 ft
(2.31m)

12.98 ft
(3.96m)

10.04 ft
(3.06m)

3.48 ft
(1.06m)

For finish & fabric options, see page 36.

ITEM NO.	SIZE	WEIGHT	CANOPY SHAPE	RIBS	FEATURES	MSRP
JCP301-30S	10 ft x 10 ft (3.0m x 3.0m)	74 lbs.	Square	8	<ul style="list-style-type: none"> Aluminum 360° Rotation Crank Lift System Infinite Tilt (front to back, left to right) Self-Locking Canopy Fasteners Single Wind Vent Internal Mast Stem Cover Protective Cover 	\$3,570
JCP301-35	11.5 ft (3.5m)	84 lbs.	Octagon	8		\$3,570
ITEM NO.	DESCRIPTION	WEIGHT	SIZE		FEATURES	MSRP
JCB301	Freestanding Base	350 lbs.	39.37" x 39.37" x 6.29"		<ul style="list-style-type: none"> Powder Coated Hot Galvanized Steel Base 3.75" Locking Wheels 	\$3,125*

*Compatible base or mount kit must be purchased with frame & canopy. For available mount kit options, see page 37.











SHOWN: JCP401-40 (MW - Matte White) in 10022 Natté Grey Chiné

JCP.401 SIDEPOST ALU



Infinite Tilt
Front to Back

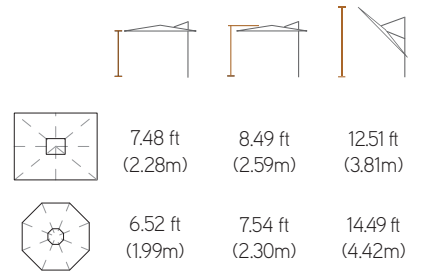

For finish & fabric options, see page 36.

ITEM NO.	SIZE	WEIGHT	CANOPY SHAPE	RIBS	FEATURES	MSRP
JCP401-343RT	10 ft x 14 ft (3.0m x 4.3m)	134 lbs.	Rectangle	8	<ul style="list-style-type: none"> Aluminum 360° Rotation Crank Lift System Infinite Tilt (front to back) Self-Locking Canopy Fasteners Single Wind Vent Internal Mast Stem Cover Protective Cover 	\$7,350
JCP401-40	13 ft (4.0m)	134 lbs.	Octagon	8		\$7,350
ITEM NO.	DESCRIPTION	WEIGHT	SIZE		FEATURES	MSRP
JCB401	Freestanding Base	540 lbs.	39.37" x 39.37" x 7.08"		<ul style="list-style-type: none"> Powder Coated Hot Galvanized Steel Base 3.75" Locking Wheels 	\$4,060*

*Compatible base or mount kit must be purchased with frame & canopy. For available mount kit options, see page 37.







JCP.501





SHOWN: JCP501 (TK - Alu Teak) in 5404 Natural

JCP.501 QUAD SIDEPOST ALU

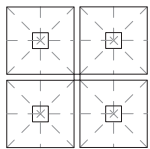

JCP501

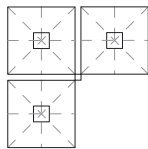

JCP501-P3

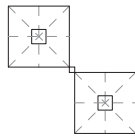

JCP501-P2

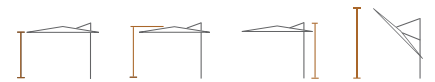

7.50 ft
(2.29m)

8.25 ft
(2.51m)

9.75 ft
(2.97m)

16.33 ft
(4.98m)

For finish & fabric options, see page 36.

ITEM NO.	DESCRIPTION	WEIGHT	CANOPY SHAPE	RIBS	FEATURES	MSRP
JCP501	Frame & (4) Canopies	393 lbs.	Square 10 ft.	8 per canopy	<ul style="list-style-type: none"> Aluminum Up to 430.5 sq. ft. of Coverage Crank Lift System Infinite Tilt (front to back) Each Canopy Opens and Tilts Individually <ul style="list-style-type: none"> Self-Locking Canopy Fasteners Single Wind Vent Internal Mast Stem Cover Protective Cover 	\$15,880*
JCP501-P3	Frame & (3) Canopies	320 lbs.				\$12,610*
JCP501-P2	Frame & (2) Canopies	247 lbs.				\$9,330*

*Mount kit must be purchased with frame & canopy. For mount kit option, see page 37.



Gutters connect JCP.501 canopies together to span big surfaces and canalize rain-water.

For optional (one-piece) Gutters, see page **39**.



FINISHES & FABRICS

Finishes



SS
Silver Anodized



CC
Charcoal



MW
Matte White
(Special Order)



TK
Alu Teak
Not available on JCP201
(Special Order, 5% Upcharge)

Fabrics



10020
Natté
White

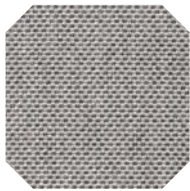

10022
Natté
Grey Chiné

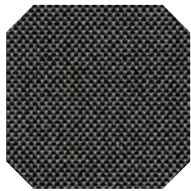

10059
Natté
Dark Taupe

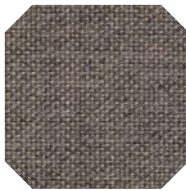

10065
Natté
Carbon Beige



5403
Jockey
Red



5404
Natural



5408
Black



5416
Aruba



5417
Tuscan



5439
Navy



5476
Heather
Beige



40428
Cast Ash

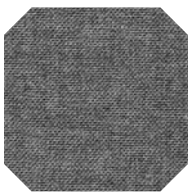

40434
Cast Slate

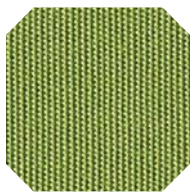

54011
Ginkgo

*Sunbrella® Furniture Grade (non-stock) fabrics available.
(Special Order, 10% Upcharge)*

Call for availability.

NOTE: Fabric and finishes shown are not to scale. Colors may vary slightly from the actual fabric and finish; please refer to the actual fabric swatch and frame sample to view true color and detail.

BASE & MOUNT OPTIONS

Compatible Base with Locking Wheels

Base finish matches frame finish except for TK (Alu Teak) which uses the CC (Charcoal) finish.



Locking all weather wheels rotate 360°.

ITEM NO.	DESCRIPTION	SIZE	WEIGHT	FEATURES	MSRP
JCB101	Freestanding Base	19.68" x 19.68" x 3.14"	100 lbs.	<ul style="list-style-type: none"> • Powder Coated • Hot Galvanized Steel Base • Locking Wheels 	\$1,130*
JCB201		39.37" x 39.37" x 6.29"	350 lbs.		\$3,125*
JCB301		39.37" x 39.37" x 6.29"	350 lbs.		\$3,125*
JCB401		39.37" x 39.37" x 7.08"	540 lbs.		\$4,060*

*Compatible base must be purchased with frame & canopy. Compatible base not available for JCP.501.

Compatible Mount Kits

Mount Kit options for concrete and in-ground mounting.

SERIES	MOUNT KIT	ITEM NO.	WEIGHT	CUBE	MSRP
JCP.201 JCP.301	Concrete**	JCB-MKC21	10 lbs.	0.53	\$385***
	In-Ground	JCB-MKG16	14 lbs.	1.40	\$265***
JCP.401 JCP.501	Concrete**	JCB-MKC25	14 lbs.	0.77	\$600***
	In-Ground	JCB-MKG25	22 lbs.	2.77	\$485***

**Available in CC - Charcoal & 5T - Platinum.
MUST CHOOSE FINISH WHEN ORDERING.

***Compatible mount kit must be purchased
with frame & canopy.

Mount kit not available for JCP.101.

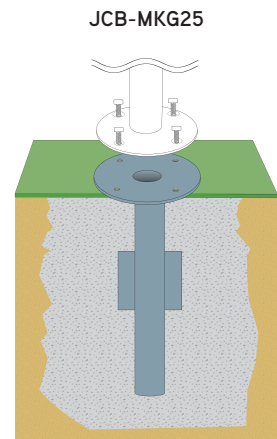
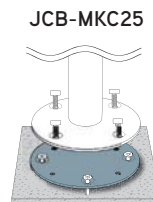
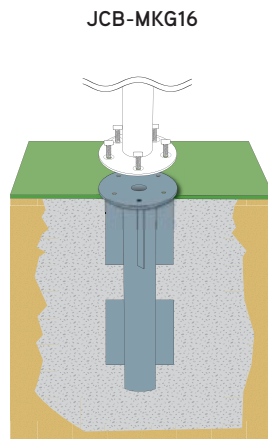
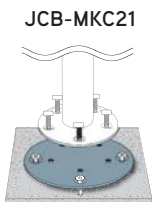

DISCLAIMER: The mount kit should only be professionally installed by a licensed contractor. Jardinico® assumes no liability and expressly disclaims any responsibility for injuries or damages arising from or related to the failure of buyer to have the mount kit installed by a licensed professional contractor. Jardinico makes no warranty except as expressly stated herein, and no warranty except Title to Materials furnished shall be implied with respect to this order.

DISCLAIMER OF WARRANTIES: Except as herein expressly set forth, this product is sold "as is" and "with all faults", and without any implied warranty of merchantability -- which warranty is hereby expressly excluded. This product is sold without any implied warranty of fitness for a particular purpose -- which warranty is hereby expressly excluded. Moreover, there are no warranties which extend beyond the description on the face hereof.

ACCESSORIES

ANTIBES WINE TUB



ITEM NO.	HEIGHT	WIDTH	WEIGHT	CUBE	MSRP
JCA-ANT-WTB	9.5"	18.13"	20 lbs.	4.14	\$680

ANTIBES WINE COOLER



ITEM NO.	HEIGHT	WIDTH	WEIGHT	CUBE	MSRP
JCA-ANT-WCO	11.5"	10.63"	9 lbs.	1.64	\$380

ANTIBES LANTERN



ITEM NO.	SIZE	HEIGHT	WIDTH	WEIGHT	CUBE	MSRP
JCA-ANT-SM	Small	15.7"	8.0"	13 lbs.	1.85	\$250
JCA-ANT-MD	Medium	19.7"	8.0"	15 lbs.	2.17	\$400
JCA-ANT-LG	Large	31.5"	12.5"	34 lbs.	5.73	\$690

MOROCCAN LANTERN



ITEM NO.	SIZE	HEIGHT	WIDTH	WEIGHT	CUBE	MSRP
JCA-MOR-SM	Small	15.0"	11.0"	10 lbs.	2.52	\$170
JCA-MOR-MD	Medium	19.7"	11.0"	12 lbs.	3.02	\$200
JCA-MOR-LG	Large	26.8"	11.0"	14 lbs.	3.52	\$250



Lights sold separately

REPLACEMENT PARTS & OPTIONS

Replacement Protective Covers

SERIES	ITEM NO.	MSRP
JCP.101	JA-CP902	\$145
JCP.301	JA-CD35D	\$175
JCP.401	JA-CD36-02	\$215
JCP.501	JA-CD39	\$400



Replacement Canopy

SERIES	FRAME	ITEM NO.	MSRP
JCP.101	JCP101-23S	CJ1-23SQ	\$935
	JCP101-28	CJ1-28H	\$945
JCP.201	JCP201-45	CJ2-45	\$3,490
JCP.301	JCP301-30S	CJ3-30SQ	\$1,540
	JCP301-35	CJ3-35	\$1,540
JCP.401	JCP401-343RT	CJ4-343RT	\$3,185
	JCP401-40	CJ4-40	\$3,085
JCP.501	JCP501	CJ5-30SQ	\$1,540 ea.

Optional (one-piece) Gutter

Gutters connect JCP.501 canopies together to span big surfaces and canalize rain-water.



ITEM NO.	MSRP
JCG	\$615 ea.

MAINTENANCE

MAINTAINING THE FRAME AND FITTINGS

1. Hose mast and frame with water periodically, more often if installation is in a salty or industrial environment.
2. Inspect the installation fittings, mount bolts, rib spacers, etc. on a regular basis and tighten if necessary.
3. Seaside and indoor pool use: Due to demands of both of these environments, Jardinico recommends weekly or biweekly cleaning with mild soap and water to remove the concentrated deposits and protect the powder coat finish.

MAINTAINING THE CANOPY FABRIC

1. Clean up spills and stains right away. Spills can be removed by using a clean absorbent cloth.
2. For general maintenance, use a soft brush to remove dust and dry soil. Wash down with clean, warm water (i.e., garden hose) every so often to avoid dirt becoming ingrained. Allow the fabric to air dry before closing the canopy.
3. If a thorough cleaning is necessary, sponge over the fabric using a mild soap solution (2% solution). Rinse well with plenty of water to remove all soap residue.
4. Never use detergents, cleaning fluids or solvents.
5. Please visit the fabric websites for more details: www.jardinicousa.com or www.sunbrella.com
6. Use protective canopy cover during storage or when not in use.

As a condition of doing business with Treasure Garden, Inc. and its affiliates (hereinafter, "TG") all persons involved in the commercial purchase, sale, or resale of TG products (each, a "Dealer") shall be bound by the following terms and conditions (the "Agreement").

Distribution:

- To qualify as an authorized TG retail Dealer a business must:
 - Have a permanent store-front retail business location with reasonable space to display TG products and accessories.
 - Maintain an inventory of TG merchandise throughout their outdoor product selling season.
 - Reasonably accommodate purchases of anyone showing interest in TG products.
 - Be moderately capable of "after the sale" service and support to the end-user and reasonably accommodating of consumer requests for such service and support.
 - Retail Dealers should be qualified or trained by their TG sales representative.

TG reserves the right to respond to geographic and individual market and competitive situations by applying different policies to its various Dealers. TG also reserves the right to rescind or modify, in its sole and absolute discretion, any existing or future sales program or policy, or the credit terms (if any) extended to a Dealer. In addition, TG may terminate any authorized Dealer, for any reason or no reason, in its sole and absolute discretion and without notice.

Prices:

Prices listed in the catalog are suggested retail prices. A Dealer's cost is based on the designated Dealer classification. Ask your Sales Representative for details regarding TG's 2022 programs and pricing structure.

Taxes and Surcharges:

The Manufacturer's Suggested Retail Price ("MSRP") does not include any state tax, local tax or surcharges. California sales tax may apply to shipments made within California, picked up at our California facility or drop shipped within the state of California unless we have a CA resale certification on file. For shipments out of CA the appropriate sales taxes will be added to acknowledgements or invoices unless we are provided with a valid State sales tax exemption certificate. Sales taxes will be added based on the address where the product is being shipped to. We collect sales tax in our nexus states, as of January 2020 our nexus states are AR, AZ, CA, CO, CT, FL, GA, IA, ID, IL, IN, KY, LA, MA, MD, ME, MI, MN, MO, NC, NE, NJ, NM, NV, NY, OH, OK, PA, RI, SC, TN, TX, UT, VA, WA & WI. Please note that CA, MA & MI will not accept another states resale certification or resale number for tax exempt purposes.

Order Acceptance:

We accept orders from an authorized retail Dealer or contract accounts only. Ask your sales representative for details on becoming an authorized retail Dealer or contract account. If you place an order with Treasure Garden and you or your designee accepts delivery of any goods in relation to the order (whether or not you believe the delivery conforms with the order) you will be bound by the terms and conditions of our 2022 catalog.

If you do not accept all of the Catalog Terms you must notify us in writing within 10 days of receiving your acknowledgement or the goods, whichever occurs sooner, to cancel or return the order at your expense. If you fail to do so, you will be bound by the Catalog Terms. In the event of a conflict between the terms on any purchase order, invoice, acknowledgement, or other document and the Catalog Terms, the Catalog Terms will prevail.

Order Policy:

- To ensure that your order is processed without delay we require:
 - A written purchase order (no phone orders) from an authorized Dealer including the business name, account number, phone number and purchase order number.
 - Ship date and specific shipping instructions. If you request freight collect or 3rd party billing, please provide the account number.
 - Our item/style number, fabric number, type and color.
 - Quantity of each style.
 - Customer's name on all Special Orders.

A 50% deposit may be required for orders that contain custom, non-stock fabrics or large quantities. The deposit must be made before the order is scheduled into our system.

Please note that any discrepancies in your purchase order can cause significant delays. You must review the acknowledgment for accuracy and advise TG immediately of any discrepancies or changes. Lead time starts once order is finalized.

Changes/Cancellations:

No cancellations, changes, additions or holds will be accepted for an order for which materials have been ordered or produced. Cancellations and/or changes of product or shipping dates on custom orders must be received in writing within 3 business days of the acknowledgement date. No cancellations or revisions will be accepted after 72 hours for non-stock fabric orders. NO EXCEPTIONS. Orders that do not follow these guidelines will be charged a 25% re-stocking or handling fee. We cannot guarantee that purchase orders added to an existing order will be shipped together. If items are added to an order or an item on an order is changed, the entire order may be rescheduled as of the date of the change. This may result in a later ship date than the original order. In the event an order is refused and returned to us, a 25% restocking/handling fee may be assessed in addition to the inbound and outbound freight charges. The 25% restock fee also applies to pro forma orders that are cancelled due to nonpayment.

Container Orders:

Due to the special pricing on container orders, all containers must be prepaid via wire transfer or paid by letter of credit. If you have not placed a prior container order or if there were previous payment delays or if there are non-stock/custom items on the order, we may require a 50% deposit before we start manufacturing the order. The remaining balance will be due two weeks before the order is shipped. The purchase of a container may also involve bank charges and other charges unrelated to the price of the product including but not limited to duties, storage, shipping and transportation charges, third party inspection charges whether inspected at point of origin, point of entry or point of delivery. Once your purchase order is sent in, we start reviewing and scheduling your order into our production schedule. It is important that you inform the Baldwin Park office of any order changes within 10 business days from when your order is sent in. After reviewing your purchase order, we will mail or fax an order acknowledgement with your payment instructions.

We must be informed of any discrepancies or revisions to CONTAINER ORDERS in writing within 10 business days of sales order acknowledgment date. No cancellations are allowed. When placing orders, please be mindful of Chinese New Year. Generally, our manufacturing schedule is tight around that time.

Back Order/Partial Shipments:

Due to the considerable number of items we offer, we may not initially be able to ship or deliver your entire order. In such event the balance and/or entire order thereof will be back-ordered and shipped and delivered at a subsequent time or times. Standard shipping charges will apply to partial or back order shipments.

Lead Times:

Our goal is to ship custom in stock fabric orders within 6-8 weeks of the acknowledgement of the order, 8-10 weeks for non stock fabrics. Notwithstanding anything to the contrary herein, TG does not guarantee that any shipments of any type of product or order will be delivered at or before a date certain. All large quantities may result in partial shipments. This is a goal – not a guarantee – and may be slightly affected by availability of fabrics & consumer demands.

ALL SHIPMENTS - TG shall, in the event of no routing instructions from the buyer; select a carrier, which it feels, in its sole discretion, can adequately handle each shipment.

Order Scheduling:

Deliveries are subject to fire, storm, flood, war, rebellion, riot, strike or labor trouble, interruptions to transportation, perils of navigation, damage to factory, equipment of facilities, governmental mandates, including the exercise of acts of God, failure of our sources of supply in whole or in part, and other cause beyond our control. We shall not be liable for any damages or failure to deliver or delay in delivery due to any such causes. If possible we will attempt to ship merchandise the week of the requested ship dates.

However, in order to maintain an orderly schedule, we reserve the right to schedule the merchandise shipment to the nearest available production schedule and to ship accordingly.

Our regular business days are Monday through Friday.

Freight Charges:

The shipping charges on your invoice may differ from those on your acknowledgement. This is largely due to instability in today's fuel economy.

Please understand that these charges are assessed by the carrier, not TG. These charges can sometimes include fuel surcharges, lift gate, extra delivery charges, as well as standard pallet fees and box pallet fees which may not have been indicated on the preliminary freight quotes. The pallet fees may increase depending on the cost of these items.

If the freight charges are prepaid & added to your invoice, the shipping charges may include any applicable pallet charges. To ensure the most economic freight for our customers, we are constantly reviewing freight rates. If we ship your orders freight collect or 3rd party billing we will bill your company for any applicable pallet charges.

Freight Claims:

All merchandise is delivered to the carrier in factory new condition. Our FOB shipping points are Baldwin Park, CA or Ningbo, China. The FOB location depends on your order type and product availability. The carrier accepts responsibility for the safe delivery upon acceptance of the shipment. TG should be notified immediately regarding any claims. Claims for loss or damage sustained in transit must be filed by the Dealer, as follows:

Visible Damage:

It is the Dealer's responsibility to check the merchandise and file a claim with the carrier if the shipment was made using the dealer's carrier and account. Request a claim form from the delivering carrier and file your claim immediately. If the shipment was made using TG's carrier and account, it is the Dealer's responsibility to check the merchandise and notify TG immediately of the situation so that a claim can be filed. In either situation, make a notation on the Bill of Lading as to the nature and extent of the damage and obtain a signature of the carrier's agent. (Failure to adequately describe this information may result in the carrier refusing to honor the claim and TG will not, under any circumstances, be liable for damage sustained in transit).

Concealed Damage:

If damage is discovered when unpacking the merchandise, immediately mark the damaged area and submit a written request for the carrier to inspect. Attach a copy of the concealed damage information. Do not remove the merchandise from the original carton until the carrier inspection is complete. If the merchandise was shipped using TG's carrier and account, it is the Dealer's responsibility to notify TG immediately of the situation so that a claim can be filed. Concealed damage needs to be reported and claim filed within 5 days for all carriers.

Shortage:

It is the Dealer's responsibility to inspect all merchandise and to file claims with the carrier in the event of product shortage. Make a notation on the Bill of Lading as to the number of cartons short. TG must also be notified immediately of any shortages. File the claim with the delivery carrier immediately. No claim for shortages, damaged items or errors will be honored unless it is made in writing on the Bill of Lading immediately upon receipt of the shipment. Notwithstanding anything to the contrary in this Agreement, failure to make a claim on the Bill of Lading will constitute a waiver of any rights to a refund or credit.

Return Goods:

No returns will be accepted without a written Return Authorization (RA#) from the factory. A request for return must be done within 30 days of delivery and all RA's are valid for 60 days.

It is the Dealer's responsibility to follow routing instructions. Please fax in a request for an RA#. Your request must include the following information:

- Company name, contact name, number & store hours;
- The TG invoice and/or acknowledgement;
- The item no., number of units to be returned and carton total;
- The reason for the return; and
- Which carrier will be returning the goods and the date of the shipment.

Any item that is returned for credit that is not under TG's warranty policy is subject to a 25% restocking fee (and must be properly packaged) plus inbound and outbound freight charges, if applicable. Any item that is returned for repair or replacement that is not under TG's warranty policy is subject to the applicable repair charges listed in the "Other Fees" section below. FOR FULL CREDIT CONSIDERATION, RETURNED MERCHANDISE MUST BE BOXED & IN NEW CONDITION TG will only organize the return of product for warranty determination from the original point of shipment within the US and Canada. Per the Treasure Garden Limited Warranty, Treasure Garden restricts warranty service for TG products to the country where Treasure Garden or its authorized TG retail Dealers originally sold the product.

Errors:

There may be errors in the prices, descriptions or images of certain merchandise in our catalog or sales material. We reserve the right to restrict orders of those items.

Other Fees:

These fees apply to both contract accounts and retail Dealers.

- Non-warranty repairs are subject to a labor charge of \$35 per hour plus applicable parts, inbound and outbound freight charges. Please allow at least 5 business days for processing.
- A \$15 handling fee will be added to any purchase under \$50. To avoid this fee, please accumulate your product needs and place orders together. DOES NOT APPLY TO PARTS, FABRIC BY THE YARD OR DISPLAY STANDS.
- A \$15 drop shipment fee will be added to drop shipment orders. We can drop ship orders to US addresses only. The appropriate sales and use tax will be added to the orders unless we have a resale certification for the state that the items are being shipped to. Depending on the item, additional delivery charges may apply. TG reserves the right to rescind or modify, at its sole discretion, drop shipments or the drop shipment of specific items.
- A \$25 service charge will be assessed on any returned check.
- Residential delivery fees, lift-gate fees, limited access and "call before delivery" fees vary depending on the carrier.
- A Materials Handling Fee may be assessed for palletized orders shipping LTL freight collect or when special labels are required to print for each order.

Shipping:

Most TG products can be shipped using parcel companies (UPS, FedEx or other). Some of our larger or heavier products however, must be shipped with a trucking company. Such products are identified with the "Truck Only". TG can only ship to addresses in the US and Canada. If shipping to Canada, you must have your own broker to clear items through customs and this information must be provided with the purchase order.

Treasure Garden Storage Policy:

We reserve the right to assess storage fees if you are not able to receive the product when Treasure Garden is ready to ship, your carrier does not pick up within 3 days of notification that the shipment is ready or after a 3-day grace period*. The grace period starts the day after the original Estimated Ship Date on your Order Acknowledgement (or the date the product is ready to ship). When the grace period expires, the following storage policy and pricing will be applied:

- Un-palletized orders are \$50 per day*
- Palletized orders are \$50 per day*; plus an additional \$20 per pallet

*All time frames referenced in policy are business days

† Customer is responsible for all shipping charges if they are unable to receive shipment when carrier is ready to deliver. This includes but is not limited to, storage and re-delivery fees.

†† Storage is not available for Cash In Advance customers.

Payments:

Payment will be accepted in US Dollars only. If a deposit or pre-payment is paid by a standard business check drawn on a domestic banking institution, please allow 2-5 business days from TG's deposit date for your funds to clear. If paid by a standard business check drawn on an International banking institution, please allow 4-6 weeks from TG's deposit date for your funds to clear. If your deposit is prepaid via wire transfer, please allow 1 business day for your funds to clear. Invoice payments should be sent to be received on or before the due date at our corporate office in Baldwin Park, CA at the address in the "Notices" section, below. Payments made in a different manner may be delayed.

Pricing:

"MSRP" means the Manufacturer's Suggested Retail Price as set forth in this Catalog. "MAP" means the Minimum Advertised Price as set forth in this paragraph. Dealers must adhere to MAP requirements when advertising via any traditional media, in all online advertising, online comparison price shopping, and landing pages. Dealers cannot advertise TG products below a published Net MAP price list effective the start of each fiscal year. TG reserves the right to adjust MAP pricing based on MSRP and/or MSRP pricing, changes due to tariff implementation and/or other unforeseen market conditions, as needed during the fiscal year. This net pricing is inclusive of, but not limited to, discounts such as coupons, promo codes, email "sign up" discounts and sales tax. In addition, no advertisements may state or otherwise suggest that the TG MSRP is higher than the actual MSRP as set forth in this catalog. It is also incumbent on all dealers to update their pricing January 15, 2022 for 2022 season to reflect any changes to MSRP and MAP that might occur. MAP Policy may vary for international dealers, please see your local sales representatives for details.

Minimum Advertised Price Requirements:

As in any Minimum Advertised Price ("MAP") program, the intent is to uphold the integrity of the Treasure Garden line of products and protect the investments made by Treasure Garden and its Dealers and retail partners. Violating MAP requirements only serves to devalue the brand in the eyes of the consumer. These MAP requirements apply to any Dealers advertising TG products via traditional media including, but not limited to, newspapers, mailers, inserts, circulars, magazines, catalogs, television and radio. In addition, the MAP requirements apply to any Dealers selling or advertising TG products online and/or having a checkout/cart system.

MAP Policy Violation Enforcement:

TG reserves the right to determine, in its sole and unfettered discretion, whether a violation of the MAP requirements has occurred. If TG determines that a Dealer has violated the MAP requirements, TG may, in its sole and unfettered discretion, terminate its relationship with the Dealer without notice or an opportunity to cure. The Dealer agrees that money damages or other legal remedies would not, standing alone, be a sufficient or adequate remedy for any breach or violation of the MAP requirements. As such, in addition to all other remedies available to TG, TG shall be entitled to an injunction restraining such breach or violation and to other equitable relief, including specific performance, without a bond or other security being required.

Product Advertising:

All TG products advertised may include the Treasure Garden name in the product description. Product advertising may include proprietary names (e.g., O'bravia®, Solefin®, etc.) and the Treasure Garden logo in product descriptions. Product names cannot be changed without prior approval (e.g. EVO, Polaris, etc.). Dealers may use their own images of TG products that they have taken themselves OR use images offered in TeamTG. Treasure Garden logos and logos of proprietary products will be provided on TeamTG. Lifestyle images provided by Treasure Garden should not be altered without prior approval. The Dealer's permission to use the Treasure Garden brand, trade names, logos, images, and any intellectual property is subject to the Dealer's strict compliance with this Agreement including, but not limited to, the MAP requirements.

Bulk Sale Restrictions:

If a Dealer decides to resell product to a third party said Dealer is responsible for any warranty or service issues, as well as is still bound to this agreement. The third party is not under agreement with TG, it is the Dealer that is doing business with TG.

Duty to Notify TG of Complaints:

Dealers shall make a careful and thorough inspection of all goods received. Subject to and without limitation of the requirements of the "Freight Claims" section above, Dealers must notify TG in writing of any complaints or issues, whether existing or reasonably foreseeable, relating to TG's performance including, but not limited to, discrepancies in quantity or description of items delivered, defects or potential defects in items delivered, or any other issue whatsoever relating to TG's performance (except issues relating to billing disputes, which are dealt with in the next section.) Notice shall be provided to TG within 30 days of:

(i) the Dealer's receipt of any defective or non-conforming goods, or (ii) the time any other issue complained of came, or should, with reasonable care, have come to Dealer's attention – whichever is earlier. Unless timely notification is received by TG in accordance with the terms hereof, which notice shall identify with particularity all complaints or issues asserted by the Dealer, the Dealer irrevocably waives any and all complaints relating to any defective or non-conforming product or any other issue whatsoever relating to TG's performance and the Dealer shall have no recourse against TG. The Dealer shall be solely responsible for retaining proof that the written notice required by this section was received by TG.

Payment Obligations:

Dealers agree to examine immediately upon receipt each of TG's statements of account, invoices, or other billing statements (collectively, "Bills"), and to notify TG in writing of any disputed Bills within 10 days of receipt. Such disputes may include, but are not limited to, disputes relating to charges for items that were billed but not received; charges for product that was received but not ordered; or charges for items that were returned, refused, credited, or have a freight claim pending. Dealers will not withhold payment when disputes arise. Only the disputed portion of a timely disputed past-due balance may be withheld. Unless timely notification is provided to TG in accordance with the terms hereof, which notice shall identify with particularity any and all objections to any of TG's Bills, the Dealer irrevocably waives any and all objections to TG's Bills. In addition, the Dealer agrees that its obligation to pay TG is separate and independent from any obligations TG may have to the Dealer. In the event the Dealer fails to pay TG in accordance with the terms hereof, the Dealer irrevocably waives the right to assert any and all claims, offsets, or any other defenses whatsoever to TG's right to payment. The Dealer further agrees that any payments to TG may be applied to any invoices or other indebtedness owed to TG, in

TG's sole and absolute discretion. The Dealer shall be solely responsible for retaining proof that the written notice required by this section was received by TG.

Statements are sent on the 1st business day of each month.

Attorneys' Fees:

The Dealer agrees that it shall be liable for all of TG's attorneys' fees (including local counsel fees), experts' fees, accountants' fees, court fees, collection costs, collection agency fees (if applicable), and any other expenses, whether or not incurred in connection with litigation or arbitration, arising from the breach of any term of this agreement by the Dealer, and/or in connection with the enforcement of any judgment or award rendered in favor of TG.

Governing Law:

You agree that all matters relating to your purchase and use of TG products, including all disputes, will be governed by the laws of the United States and by the laws of the State of California without regard to its conflicts of law provisions. You agree to the personal jurisdiction by and venue in the state and federal courts in Los Angeles County, California, and waive any objection to such jurisdiction or venue.

No Waiver:

None of TG's rights hereunder will be deemed to be waived or modified in any way based upon the manner in which this Agreement is performed or TG's failure to enforce its rights hereunder or insist on strict and timely performance of the Dealer's obligations. Without limitation to the foregoing, acceptance of payment outside of the stated credit terms shall not operate as a waiver of the stated credit terms.

Limitation on Liability:

In no event will TG be liable to the Dealer for any lost profits, lost savings, or any consequential, incidental or special damages arising out of or in connection with the parties' relationship, even if TG has been put on notice of the possibility of such damages. Without limitation to the foregoing, under no circumstances will TG be liable to the Dealer for punitive damages.

Disclaimer:

Please note that TG, reserves the right to alter or modify product styles and to discontinue frames and fabrics without notice.

For more information about TG products, please contact us at: (626) 338-8810 or email: info@jardinicousa.com

Notices:

All written notices required hereunder shall be ineffective unless sent to the following addresses by Federal Express and email:

info@jardinicousa.com – and – **Jardnico**
13401 Brooks Drive
Baldwin Park, CA 91706

Headings:

Section headings are inserted for ease of reference only and shall have no effect on the interpretation of this agreement.

WARRANTY

Jardinico® manufactures all its shade styles from the finest aluminum alloys to ensure the strength, durability, and integrity of each and every style. We pride ourselves as a totally vertical operation. This means that we manufacture and produce over 90% of the components used in our products from the raw state. We can monitor every stage of the manufacturing process and maintain a consistent level of quality.

Our goal is that each and every Jardinico style will exceed your expectations.

Our **Limited Warranty** is outlined below. **NOTE: Wind damage is not covered under any manufacturer's warranty.**

5 Year Limited Warranty includes the mast, boom, head fitting, elbow, center pole/sidepost, arms, ribs, top and bottom hub and stainless steel hardware only. If there is damage under the warranty, Jardinico will replace and/or repair any item listed in this category at its discretion. Labor charges are not covered under this limited warranty.

5 Year Limited Warranty applies to Sunbrella® furniture grade fabrics. Visit www.sunbrella.com for more details. Labor charges are not covered under this limited warranty.

5 Year Limited Warranty covers the wheels, powder coat finish, rust and corrosion on all bases. If the powder coat finish flakes, bubbles, peels or loses color; Jardinico will re-finish or replace the defective base at its discretion. Normal wear and tear is not covered under this limited warranty. Labor charges are not covered under this limited warranty.

1 Year Limited Warranty covers accessories and protective covers.

What Is NOT Covered:

Failure caused by unreasonable or abusive use, or failure caused by neglect of reasonable and necessary care, and any modification to product are not covered by this warranty.

Additionally, acts of nature (including but not limited to wind, hurricanes, tornadoes, and storms) are not covered by this warranty. This warranty covers return freight of any warranted product only for the first year. This warranty gives you specific legal rights and you may have other rights which vary from state to state.

Wind Damage:

Jardinico highly recommends that no umbrella, regardless of size or weight, ever be left unattended in the open position. In windy conditions, it is further recommended that umbrellas be closed, removed from their base, and stored or laid horizontally. This will reduce the risk of personal injury, damage to your umbrella, furniture, and other belongings or property. To ensure stability of your umbrella, please observe proper placement, and use sufficient base weight. This catalog contains minimum recommendations for necessary weight for each style. Keep umbrella properly secured to umbrella base at all times. Thoroughly read and follow all provided instruction manuals.

Sufficient base weight or mount kit must be used to secure umbrellas at all times. Please see individual product pages for compatible base for free-standing applications. For JCP.501 Quad Sidepost, a Jardinico mount kit must be used to properly secure umbrella. We recommend a licensed contractor to secure the JCP.501.

WIND DAMAGE IS NOT COVERED UNDER OUR LIMITED WARRANTY.

Seaside and Indoor Pool Usage:

CAUTION: Seaside and indoor pool use, salt & chlorides can accumulate on the powder coat finish, leading to finish failure. Failure or neglect to make needed cleanings may cause paint to blister, and such failure will void limited warranty.

Irregularities in Production Process:

The possibility of "Irregularities" in the product surface may occur during the production process. However, these irregularities do not reduce the quality of the product. Jardinico monitors every stage of production to ensure a clean and consistent appearance on every part.

Rust:

Rust is a natural part of the aging process of all steel based materials and is therefore NOT considered a defect. Steel bases are designed to require minimum maintenance. Bases should be kept clean. Do not let dirt build up on the bases. Never leave bases standing in water. To keep your bases looking their best, you may wish to store them when not in use for an extended period of time.

International Returns:

If an item is found to be under warranty Jardinico shall only be responsible for ground shipping charges to the location of the product within the continental United States and Canada. Any duties, express, international or special shipping charges are at the expense of the retail dealer or consumer.

Important Restriction for Jardinico products Warranty Service: Jardinico restricts warranty service products to the country where Jardinico or its authorized retail dealers originally sold the product.

Changes/Cancellations:

No cancellations, changes, additions or holds will be accepted for an order for which materials have been ordered or produced. Cancellations and/or changes of product or shipping dates on orders must be received in writing within 5 business days of the acknowledgment date. Orders that do not follow these guidelines will be charged a 25% restocking or handling fee. Specially ordered merchandise and custom logo products cannot be cancelled, returned, or refunded. Delivery dates on custom orders are estimated only and may change because of fabric, shortages, production delays, port delays, acts of nature and availability of merchandise.

It is our policy to continuously improve designs, materials and manufacturing methods in order to provide you with the finest products. Therefore, variations in specifications, materials, prices, styles and finishes may be made without notice.

NO RETURNS ON CUSTOM UMBRELLAS.

The seller disclaims any implied warranty of merchantability.

Those filing warranty claims will be responsible for all shipping, handling, and freight charges on all claims to Jardinico in Baldwin Park, CA. All warranty claims must be submitted with the original proof of purchase, date of purchase, name of dealer, and the description of the damage. The Jardinico warranty is not transferable. Jardinico reserves the right to repair, replace, and/or redesign any product that is returned under a warranty claim.

For questions, contact Jardinico Customer Service:
626-338-8810 | info@jardinicousa.com

jardinico[®]
CARACTÈRE

SPECIFICATIONS

JCP.101 Specifications

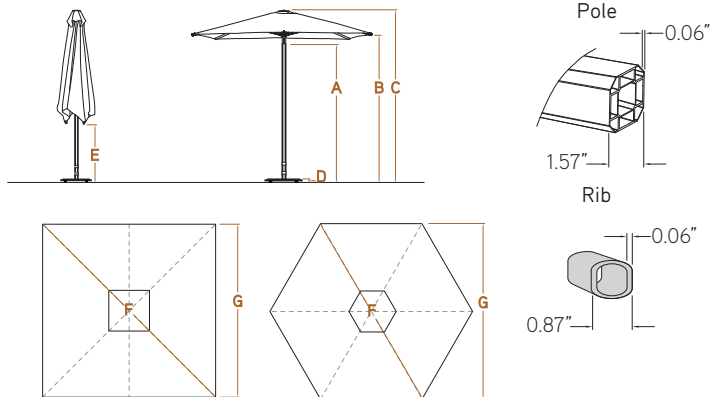

Key	Description	JCP101-23S SQUARE 7.5 ft. 2.3m	JCP101-28 HEXAGON 9 ft. 2.8m
A	Lower Hub HEIGHT (Open)	6.58 ft.	6.94 ft.
B	Rib End HEIGHT (Open)	6.69 ft.	7.08 ft.
C	Overall HEIGHT	7.71 ft.	7.90 ft.
D	Base HEIGHT	3.25 in.	3.25 in.
E	Rib End HEIGHT (Closed)	2.26 ft.	3.35 ft.
F	Canopy LENGTH (Diagonal)	10.67 ft.	9.31 ft.
G	Canopy WIDTH	7.58 ft.	8.10 ft.

Note: Measurements include JCB101 Base.

WEIGHT:	23 lbs.	27 lbs.
CUBE:	2.52	3.25

JCP.201 Specifications

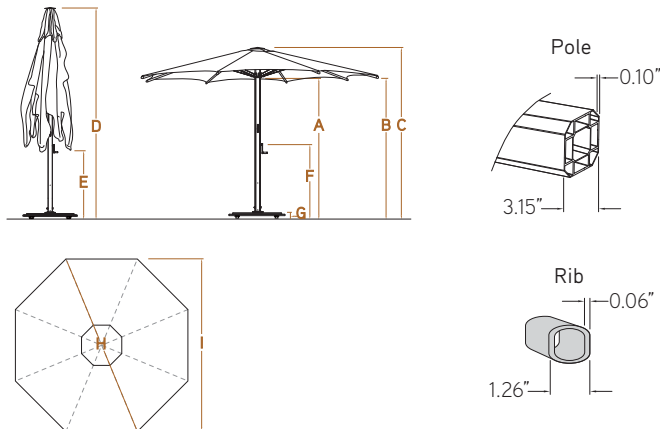

Key	Description	JCP201-45 OCTAGON 15 ft. 4.5m
A	Lower Hub HEIGHT (Open)	7.73 ft.
B	Rib End HEIGHT (Open)	8.04 ft.
C	Overall HEIGHT (Open)	9.65 ft.
D	Overall HEIGHT (Closed)	11.88 ft.
E	Rib End HEIGHT (Closed)	4.55 ft.
F	Crank Handle HEIGHT	3.83 ft.
G	Base HEIGHT	5.75 in.
H	Canopy LENGTH (Diagonal)	14.58 ft.
I	Canopy WIDTH	13.88 ft.

Note: Measurements include JCB201 Base.

WEIGHT:	82.5 lbs.
CUBE:	19.06

JCP.301 Specifications

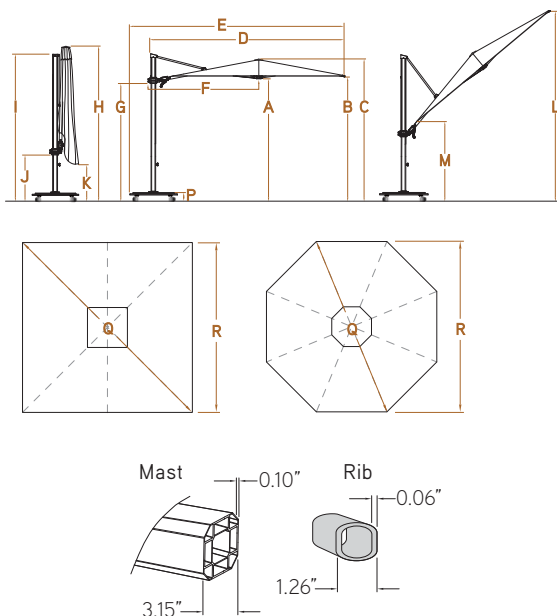

Key	Description	JCP301-30S SQUARE 10 ft. 3.0m	JCP301-35 OCTAGON 11.5 ft. 3.5m
A	Lower Hub HEIGHT (Open)	7.04 ft.	6.92 ft.
B	Rib End HEIGHT (Open)	7.33 ft.	7.50 ft.
C	Canopy HEIGHT (Open)	8.08 ft.	8.02 ft.
D	Mast to Rib End WIDTH (Open)	11.00 ft.	12.60 ft.
E	Base to Rib End WIDTH (Open)	12.33 ft.	13.75 ft.
F	Knob to Center Hub (Open)	6.29 ft.	
G	Slider Car HEIGHT (Max. Height)	6.63 ft.	6.63 ft.
H	Canopy HEIGHT (Closed)	8.40 ft.	8.75 ft.
I	Mast HEIGHT (Closed)	8.29 ft.	8.31 ft.
J	Slider Car HEIGHT (Closed)	2.10 ft.	2.27 ft.
K	Rib End HEIGHT (Closed)	1.56 ft.	2.85 ft.
L	Top Rib End HEIGHT (Max. Back Tilt)	13.08 ft.	13.42 ft.
M	Bottom Rib End HEIGHT (Max. Back Tilt)	3.54 ft.	4.63 ft.
N <small>(Not Shown)</small>	Top Rib End HEIGHT (Max. L/R Tilt)	10.17 ft.	10.48 ft.
O <small>(Not Shown)</small>	Bottom Rib End HEIGHT (Max. L/R Tilt)	4.33 ft.	3.92 ft.
P	Base HEIGHT	5.25 in.	5.25 in.
Q	Canopy LENGTH (Diagonal)	13.83 ft.	11.50 ft.
R	Canopy WIDTH	9.83 ft.	11.50 ft.

Note: Measurements include JCB301 Base.

WEIGHT:	74 lbs.	84 lbs.
CUBE:	9.19	7.5

JCP.401 Specifications

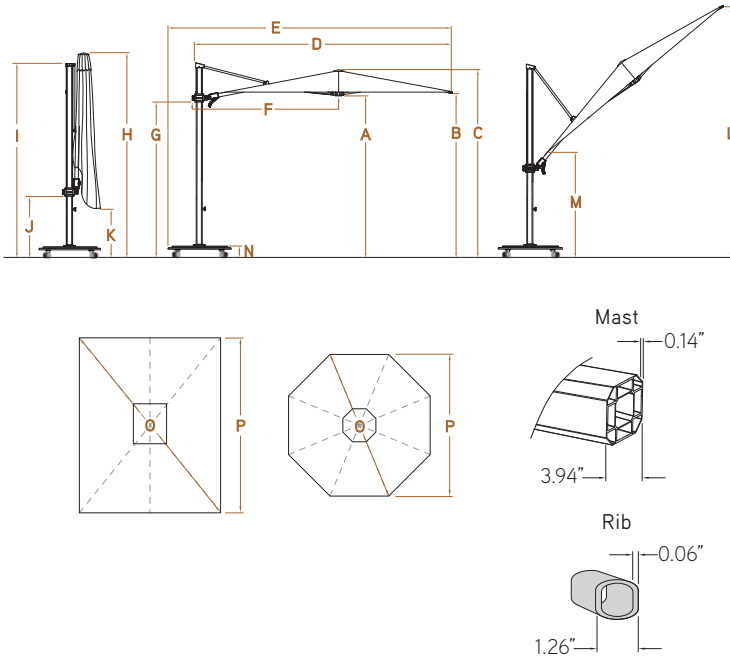

Key	Description	JCP401-343RT RECTANGLE 10ftx14ft 3.0x4.3m	JCP401-40 OCTAGON 13 ft. 4.0m
A	Lower Hub HEIGHT (Open)	7.00 ft.	7.29 ft.
B	Rib End HEIGHT (Open)	7.17 ft.	7.50 ft.
C	Canopy HEIGHT (Open)	9.13 ft.	8.67 ft.
D	Knob to Rib End WIDTH (Open)	11.17 ft.	13.92 ft.
E	Base to Rib End WIDTH (Open)	14.80 ft.	15.42 ft.
F	Knob to Center Hub (Open)	6.38 ft.	8.38 ft.
G	Slider Car HEIGHT (Max Height)	7.44 ft.	6.98 ft.
H	Canopy HEIGHT (Closed)	9.85 ft.	9.40 ft.
I	Mast HEIGHT (Closed)	9.23 ft.	8.67 ft.
J	Slider Car HEIGHT (Closed)	2.90 ft.	2.36 ft.
K	Rib End HEIGHT (Closed)	0.77 ft.	2.77 ft.
L	Top Rib End HEIGHT (Max. Back Tilt)	13.42 ft.	15.17 ft.
M	Bottom Rib End HEIGHT (Max. Back Tilt)	4.31 ft.	4.50 ft.
N	Base HEIGHT	6.25 in.	6.25 in.
O	Canopy LENGTH (Diagonal)	17.25 ft.	13.08 ft.
P	Canopy WIDTH	9.75 ft. x 13.83 ft.	11.92 ft.

Note: Measurements include JCB401 Base.

WEIGHT:	134 lbs.	134 lbs.
CUBE:	17.06	13.84

JCP.501 Specifications

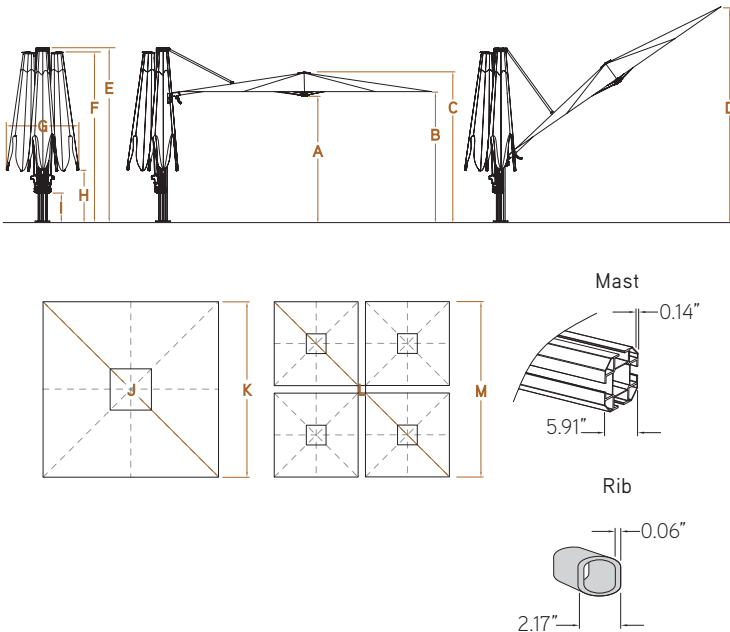

Key	Description	JCP501 SQUARE 10 ft. 3.0m
A	Lower Hub HEIGHT (Open)	7.17 ft.
B	Rib End HEIGHT (Open)	7.50 ft.
C	Canopy HEIGHT (Open)	8.25 ft.
D	Rib End HEIGHT (Max. Tilt)	16.33 ft.
E	Overall HEIGHT	9.75 ft.
F	Canopy HEIGHT (Closed)	8.33 ft.
G	Overall Canopy WIDTH (Closed)	4.84 ft.
H	Rib End HEIGHT (Closed)	2.67 ft.
I	Turning Knob (Closed)	1.75 ft.
J	Canopy LENGTH (Diagonal)	13.92 ft.
K	Canopy WIDTH	9.75 ft.
L	Overall Canopy LENGTH (Diagonal)	29.75 ft.
M	Overall WIDTH (Open)	20.83 ft.

Note: All measurements are without base

JCP501 WEIGHT:	393 lbs.
CUBE:	36.92

includes: (1) mast and (4) canopy structures.

JCP501-P3 WEIGHT:	320 lbs.
CUBE:	33.19

includes: (1) mast and (3) canopy structures.

JCP501-P2 WEIGHT:	247 lbs.
CUBE:	29.46

includes: (1) mast and (2) canopy structures.



